



Industrie Service

# CERTIFICATE

(Certificate of conformity with technical requirements in: )  
**API STANDARD 607 SEVENTH EDITION, JUNE 2016**

Certificate No.:270875

Ref. Test report No.:270876

Name and postal address of applicant: **ValPro s.r.o.**  
**Kopcianska 10, Bratislava, Slovakia**

We hereby certify that the fire test on below valves have been conducted at the laboratory designated by manufacturer and witnessed by TÜV SÜD inspector according to requirements of API STANDARD 607 SEVENTH EDITION, JUNE 2016. The testing results of valves meet the requirements of API STANDARD 607 SEVENTH EDITION, JUNE 2016.

### 1. Description of Test Valve :

Type of Test Valve	Q47N-600LB-4"-AA3 Ball Valve
Description of Test Valve	Ball Valve
Valve Size (NPS)	4"
Pressure Rating ( Class )	Class 600
Valve Body Material	ASTM A350 LF2

### 2. Qualified Range of Valves :

Type	Ball Valves
Description of Valves	Ball Valves
Qualified Sizes ( NPS ) ( according to API 607 Table 3 )	4",5",6",8"
Qualified Pressure Ratings( Class ) ( according to API 607 Table 4 )	Class 600, Class 800, Class 900
Qualified Valve Material	According to API 607 7.2
Remark: the technical data of tested valves see back of this certificate appendix 1.	

This certificate is issued according to API STANDARD 607 SEVENTH EDITION, JUNE 2016, based upon the result of testing report on above mentioned test valve. The additional valve qualification shall be limited on similar valves of same basic design and construction as the test valves and of the same nonmetallic materials as the test valve in the seat-to-closure member seal, seat-to-body seal, stem seal, and body joint and seal according to API STANDARD 607 SEVENTH EDITION, JUNE 2016, Paragraph 7.

Shanghai, July 24, 2020  
(Place, date)

*Chen Guilin*



**Guilin Chen**  
**TÜV SÜD Industrie Service GmbH**

Westendstr.199  
80686 München Germany

ZERTIFIKAT ◆ CERTIFICATE ◆ 認証証書 ◆ CERTIFICADO ◆ CERTIFICAT



Industrie Service

**Appendix 1:**

**Certificate No.:270875**

**Ref. Test report No.:270876**

**Name and postal address of applicant: ValPro s.r.o.  
Kopcianska 10, Bratislava, Slovakia**

**Technical Data of Valve**

**1. Type of Test Valve:** Q47N-600LB-4"-AA3 Ball Valve

**2. Description of Test Valve:** Ball Valve

**3. Details of Valve:**

Valves Size ( NPS ) Material	4"
Part Name	
Body	ASTM A350 LF2
Bonnet	ASTM A350 LF2
Ball	ASTM A350 LF2+ENP
Seat	DEVLON-V
Stem	ASTM A182 F6a
Gasket	SS304+Graphite
Lower Cap	ASTM A350 LF2
Packing	Graphite
Gland	ASTM A216 WCB
Nuts	ASTM A194 7
Bolts	ASTM A320 L7
Screw	ASTM A320 L7
O-Ring	VITON
Spring	INCONEL X-750
Seat Ring	ASTM A350 LF2+ENP
Design Drawing No.:	AA3 2018-06-09-01

**Shanghai, July 24, 2020**  
(Place, date)



**Guilin Chen**  
**TÜV SÜD Industrie Service GmbH**

Westendstr.199  
80686 München Germany

TÜV SÜD Industrie Service GmbH  
Shanghai Office  
Floor 3-13, No.151, Heng Tong Road,  
Shanghai 200070 P. R. China

Tel.: +86 21 6141-0123  
Fax: + 86 21 6140-8600



## Test Report

(Valve fire test according to API STANDARD 607 SEVENTH EDITION, JUNE 2016.)

Certificate No. :270875  
Test Report No.:270876

Applicant: ValPro s.r.o.  
Kopcianska 10, Bratislava, Slovakia

Inspection body: TÜV SÜD Industrie Service GmbH  
Floor 3-13, No.151, Heng Tong Road, Shanghai, P. R. China

Lab of test: Quality Inspecting Center of Pump and Valve Products of Zhejiang  
Province

Test Date: June 18, 2020

Description of valves: Q47N-600LB-4"-AA3 Ball Valve  
Size: 4"  
Pressure Rating: Class 600  
Drawing No.: AA3 2018-06-09-01

Test Witnessed By: Wang Zhilin / TÜV SÜD Inspector

## Inspection and Tests

### 1. Conformity of Equipment

The test equipment was verified by TÜV SÜD inspector according to requirements of API STANDARD 607 SEVENTH EDITION, JUNE 2016. Para.5.3 and found satisfactory. The detail arrangement of the fire-test equipment is shown below:

**Figure 1.** Typical Fire-Test System Using a Pump as the Pressure Source

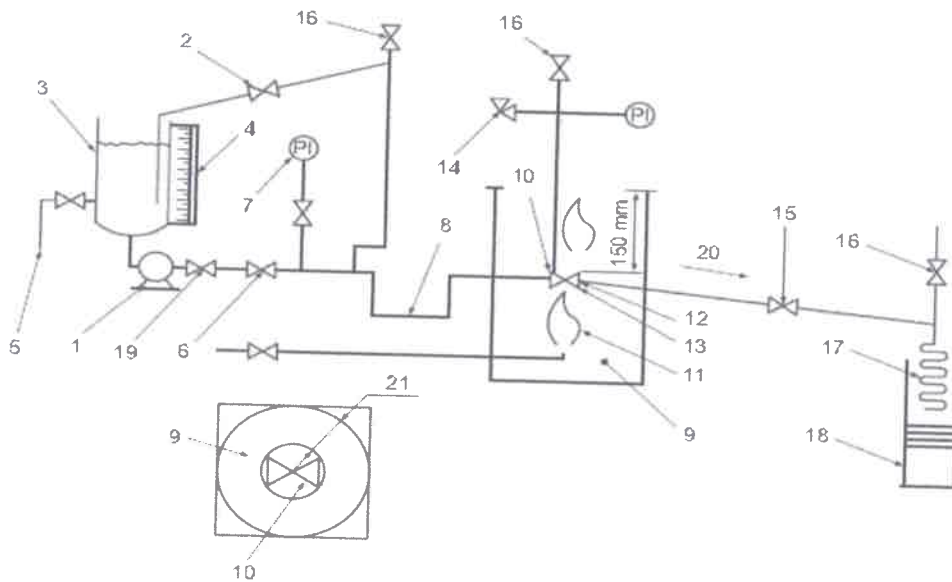

a) Pump as pressure source

#### Key

- |  |  |                       |
|--|--|-----------------------|
| 1. Pressure source                       | 10. Test valve mounted horizontally with stem in horizontal position | 19. Check valve       |
| 2. Pressure regulator and relief         | 11. Fuel gas supply and burner                                       | 20. Slope             |
| 3. Vessel for water                      | 12. Calorimeter cubes  | 21. Clearance: 150 mm |
| 4. Calibrated sight gauge                | 13. Flame environment and body thermocouples                         |                       |
| 5. Water supply                          | 14. Pressure gauge and relief valve                                  |                       |
| 6. Shut-off valve                        | 15. Shut-off valve   |                       |
| 7. Pressure gauge                        | 16. Vent valve   |                       |
| 8. Piping arranged to provide vapor trap | 17. Condenser  |                       |
| 9. Enclosure for test                    | 18. Container  |                       |



Test Report No.:270876

2. Calibration of measurement and test instrument

The measurement and test instrument have been properly calibrated such as pressure gauges, thermocouples, etc.

3. Technical Data of Test Valve:

a) Description of test valve

Type of Test Valves	Q47N-600LB-4"-AA3 Ball Valve
Description of Valves	Ball Valve
Pressure Class	Class 600
Valve Size	4"
Face to Face	ASME B16.10
Designed Standard	API6D

b) Details of technical data on test valve

Part Name	Materials
Body	ASTM A350 LF2
Bonnet	ASTM A350 LF2
Ball	ASTM A350 LF2+ENP
Seat	DEVLON-V
Stem	ASTM A182 F6a
Gasket	SS304+Graphite
Lower Cap	ASTM A350 LF2
Packing	Graphite
Gland	ASTM A216 WCB
Nuts	ASTM A194 7
Bolts	ASTM A320 L7
Screw	ASTM A320 L7
O-Ring	VITON
Spring	INCONEL X-750
Seat Ring	ASTM A350 LF2+ENP
Design Drawing No.:	AA3 2018-06-09-01



**Test Report No.: 270876**

**4. Visual and dimensional Check on Valve Specimen:**

The specimen valve was chosen at random by the manufacturer in its workshop and submitted to the laboratory. The visual and dimensional check was performed according to drawing No. AA3 2018-06-09-01 and results found satisfactory. The mark was verified on valve as following:

=	<u>4"</u>	<u>600</u>	<u>LF2</u>
Manufacturer` Brand	Size	Class	Material

**5. Document Review:**

The chemical and mechanical test report of forgings was reviewed and found satisfactory. Also the inspection report of shell test, hydro seat test and air seat test were reviewed and found satisfactory.

**6. Preparation before testing:**

- 6.1 The thermocouples and calorimeters were installed properly according to Figure 1,2,3,4 in API 607. Two thermocouples (part 13) are installed to measure flame temperature, one is located under valve body, another is located under valve stem, both within 1". Two calorimeters (part 12) are positioned to the same place as the thermocouples do.
- 6.2 The test system including test valve (part 10) was cleaned through by water before testing. All air was purged from test valve and testing system by water.
- 6.3 The test system was pressurized to 14.4 MPa after the test valve and system upstream of valve have been completely full of water and system downstream of the test valve have been completely empty of water. The system and test valve were carefully checked for leakage when the test pressure was held at 14.4 MPa. No leakage was found on system and test valve.

**7. Fire Test:**

The fire test was conducted according to API STANDARD 607 SEVENTH EDITION, JUNE 2016. Section 5. The pressure of the system upstream was kept 7.7MPa, then the fire ignited. The flame temperature reached 750°C within 2 minutes after ignition. The test pressure and temperature were maintained at 7.7MPa during the fire test. The temperature and pressure were recorded continuously by the operators. The system and test valve was cooled below 100 °C within 6 minutes by shower nozzles after 30 minutes fire test. The loss of water weight in vessel was measured by weighing scale and water in calibrated container (part 18) were read and recorded. The test result is shown as below:



Test Report No.:270876

Test result of fire test

Item	API 607 Required Value	Actual Value
Test Pressure ( MPa )	7.7MPa	7.1– 7.6MPa
Test Temperature	750 - 1000 °C	775 – 848°C
Through-valve leakage according to API 607 table 1	≤ 1600 ml / minute	70 ml / minute
Total weight of water through valve seat during cooling down period	0 ml	
Total time from fire test to cooling down	36 Minutes	
External Leakage	≤ 400 ml / minute	0 ml / minute
Conclusion: the test result is satisfactory according to API 607.		

8. Low Test:

The test valve was cooled below 100 °C within 6 minutes after complete the fire test. The low pressure test was conducted according to API STANDARD 607 SEVENTH EDITION, JUNE 2016.Para. 6.4 and 5.6.15. The test result was recorded as below:

Test result of low pressure test

Item	API 607 Required Value	Actual Value
Test Pressure ( MPa )	0.2 MPa	0.2 MPa
Test Temperature	30 °C	
Test Time	5 minutes	
External Leakage	≤ 160 ml / minute	0 ml / minute
Conclusion: the test result is satisfactory according to API 607.		

9. Operational Test:

The test valve was cooled below 100 °C within 6 minutes after complete the fire test. The operational test was conducted according to API STANDARD 607 SEVENTH EDITION, JUNE 2016.Para. 6.6 and 5.6.17. The upstream pressure was increased to 7.7MPa then the test valve was fully opened against the high test pressure differential to vent the piping and test valve body cavity to remove air or steam. The downstream shutoff valve was then closed and the system pressure was increased to and maintained at 7.7MPa. Then measured and recorded external leakage for a period of five minutes after valve was in the open position at high test pressure. The test result was recorded as below:

Test result of operational test

Item	API 607 Required Value	Actual Value
Test Pressure ( MPa )	7.7MPa	7.7MPa
Test Temperature	30 °C	
Test Time	5 minutes	
External Leakage	≤ 100 ml / minute	0 ml / minute
Conclusion: the test result is satisfactory according to API 607.		



**Test Report No.:270876**

The undersigned, hereby declare that I have checked test valve and witnessed the fire test on the test valve according to API STANDARD 607 SEVENTH EDITION, JUNE 2016. The test result is satisfactory.

TÜV SÜD Industrie Service GmbH

WANG Zhilin

Date: July 24, 2020

**Annexes:**

- 1) Copy of Drawing No. AA3 2018-06-09-01;
- 2) Copy of Test Record of Fire Test No. WFM202006129.

